

SOLIDS COLLECTION



BETONLAB
THE BEAUTY OF CONCRETE



SOLIDS COLLECTION

Due to its volume and robust perception, the Solids collection is created with its Sapphire and Agate references.

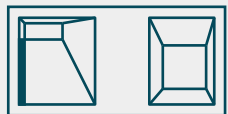

SAPPHIRE
REFERENCE



AGATE
REFERENCE

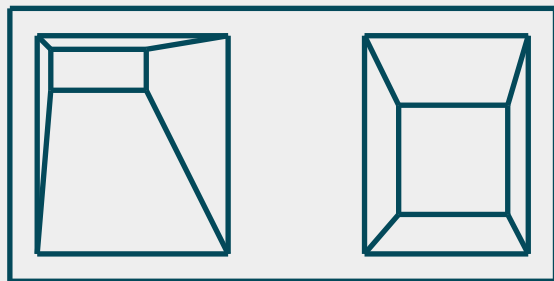

SAPPHIRE REFERENCE

The Sapphire reference allows light rays to enter through small windows, evoking the reflection that the gem produces.

SOLIDS COLLECTION

SAPPHIRE REFERENCE

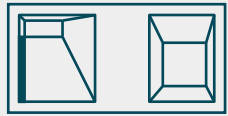

2 P

3 P

The Sapphire reference is a construction system made up of 2 pieces that help to shape the walls. Depending on which pieces are used to build the wall, it may have more or less opening percentage.

SOLIDS COLLECTION / SAPPHIRE REFERENCE

SYSTEM COMPONENTS

The pieces are made of high-strength concrete and its smooth finish gives a differential aesthetic added value. In addition to the variety of colors that we offer, we can adjust to new shades according to the client's needs.

Our primary color palette is:

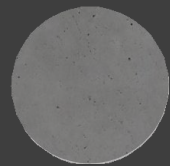

Graphite Gray



Ivory white

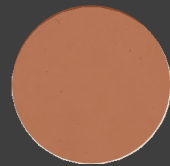

Ocher Brown

3 P

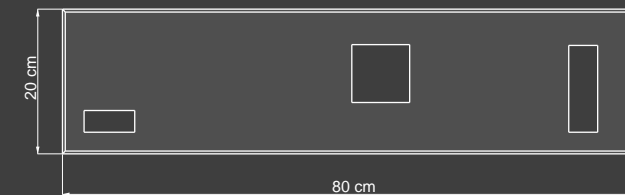
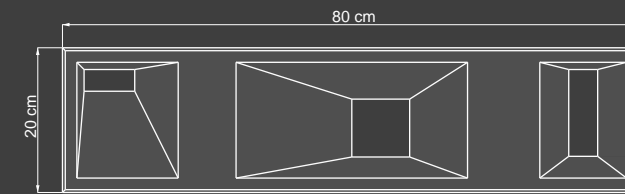

2P

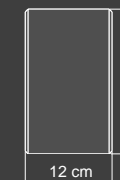
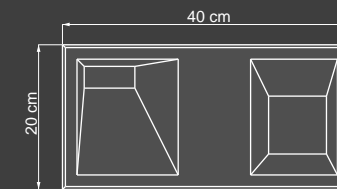

SOLIDS COLLECTION / SAPPHIRE REFERENCE

EXAMPLES OF MODULATIONS

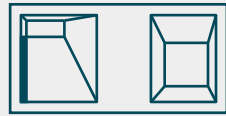

2P

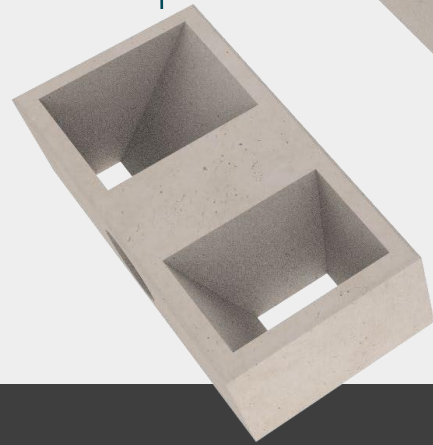

3P

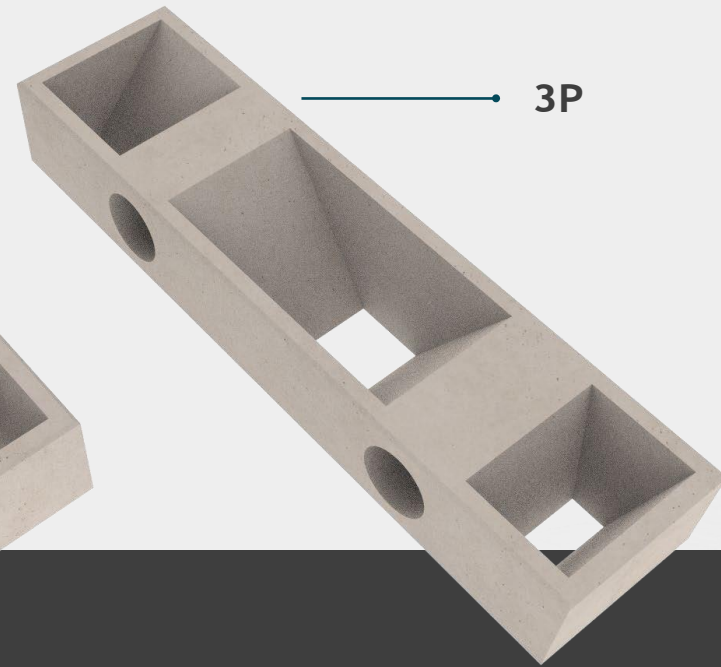

REF: SAPPHIRE 1

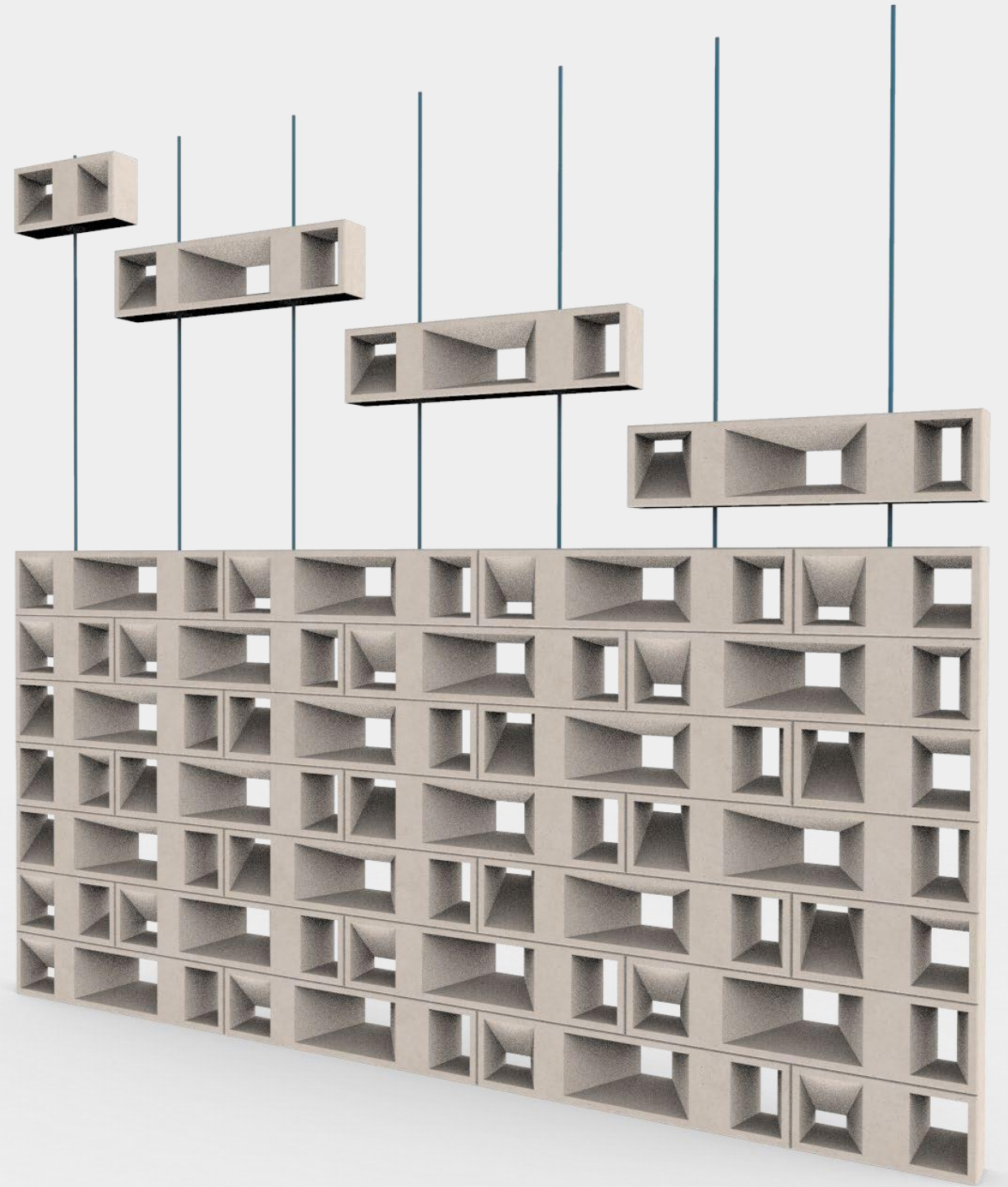

SOLIDS COLLECTION / SAPPHIRE REFERENCE

EXAMPLES OF MODULATIONS

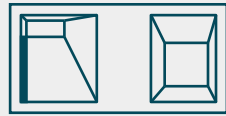

2P

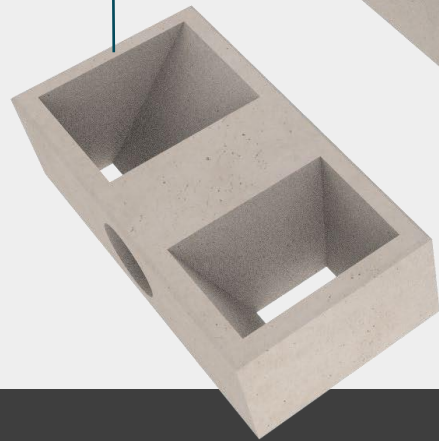

3P

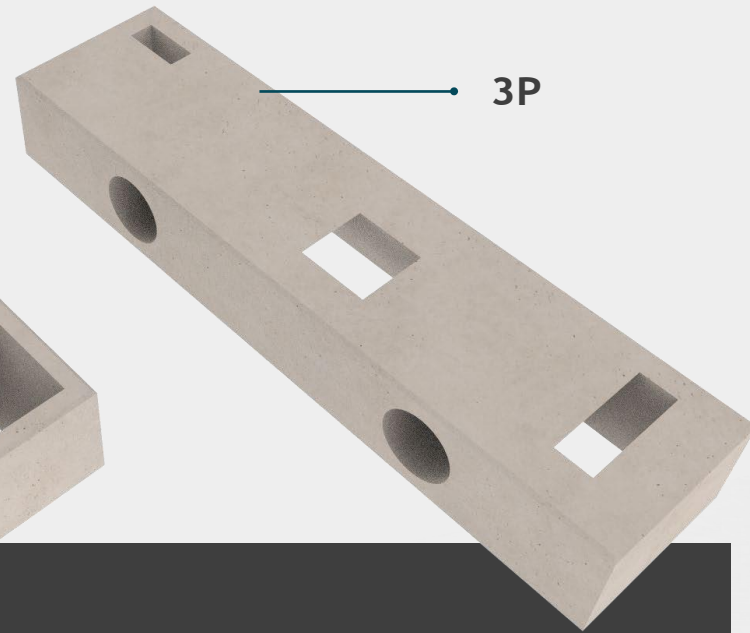

REF: SAPPHIRE 2



SOLIDS COLLECTION / SAPPHIRE COLLECTION

EXAMPLES OF MODULATIONS

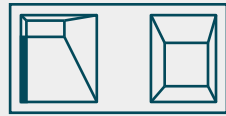

2P

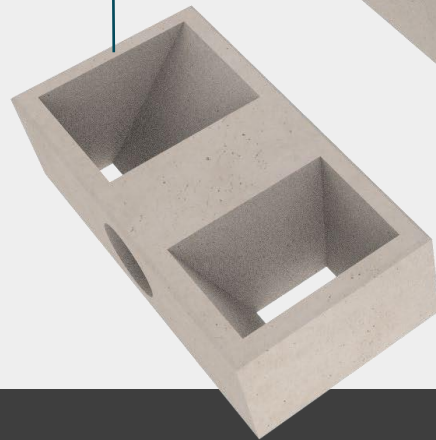

3P

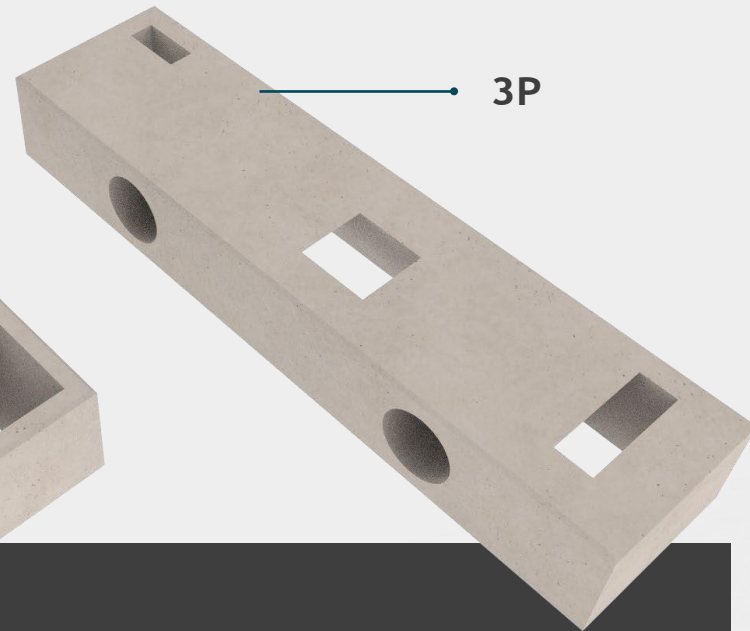

REF: SAPPHIRE 3



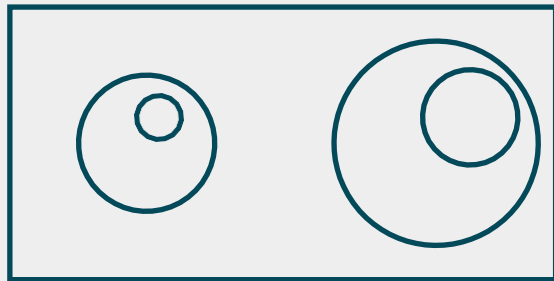

AGATE

REFERENCE

The Agate variation has rounded corners shaping the light in its own way and generating a special atmosphere inside.

SOLIDS COLLECTION

AGATE REFERENCE



2P

3P

The Agate reference is a construction system made up of 2 pieces that help to shape the walls. Depending on which pieces are used to build the wall, it may have more or less opening percentage.

SOLIDS COLLECTION / AGATE REFERENCE

SYSTEM COMPONENTS

The pieces are made of high-strength concrete and its smooth finish gives a differential aesthetic added value. In addition to the variety of colors that we offer, we can adjust to new shades according to the client's needs.

Our primary color palette is:

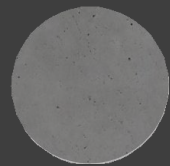

Graphite Gray



Ivory white

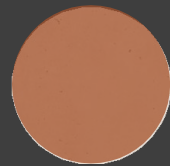

Ocher Brown

3 P

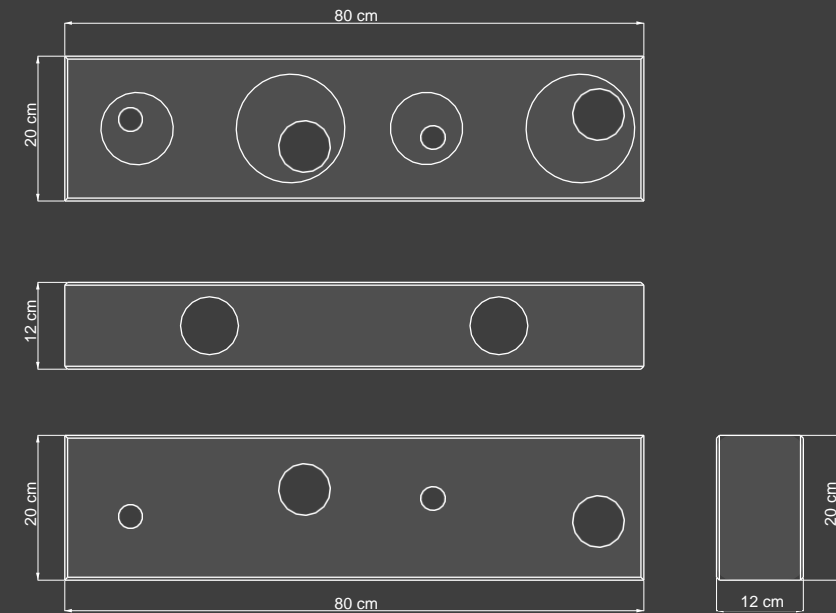

2P

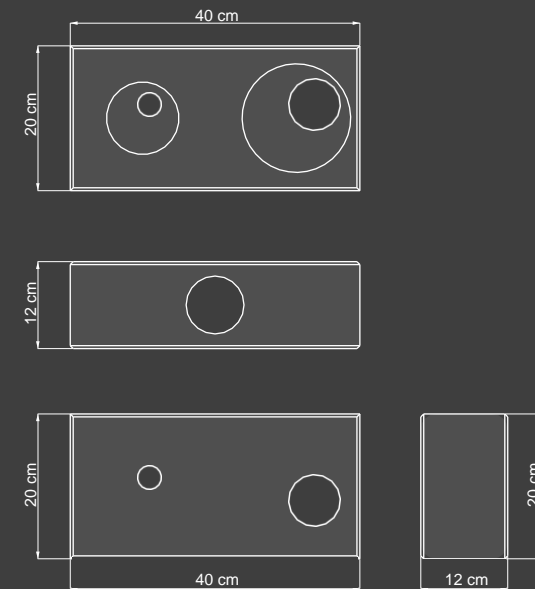

SOLIDS COLLECTION / AGATE REFERENCE

EXAMPLES OF MODULATIONS

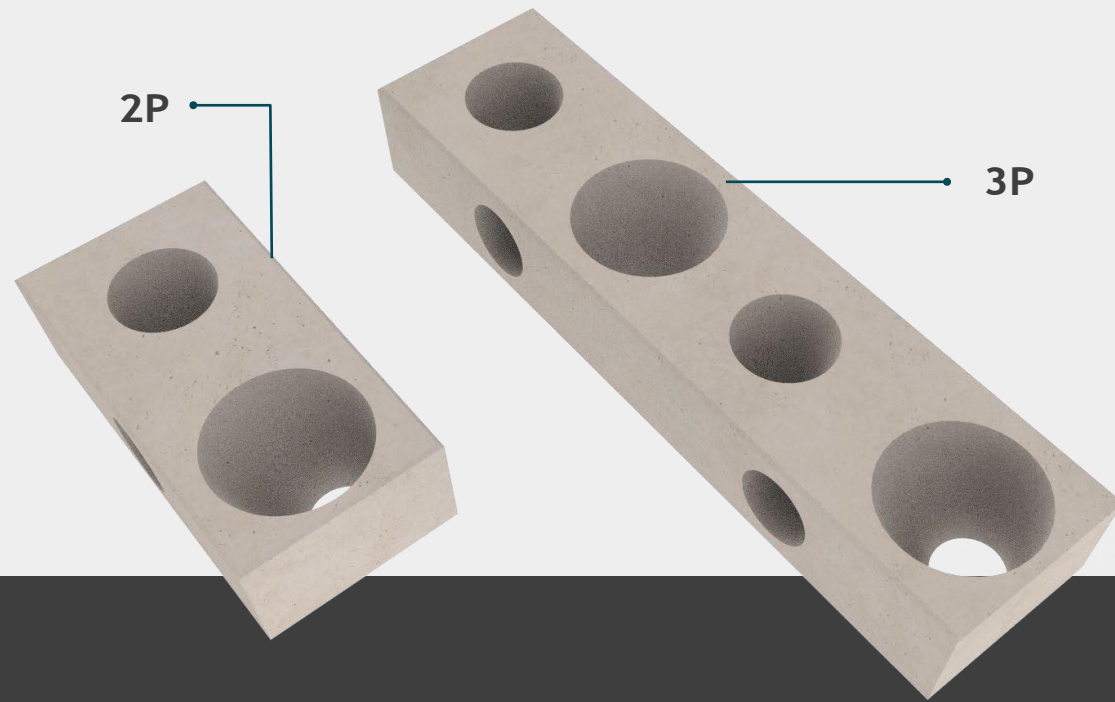

REF: AGATE 1

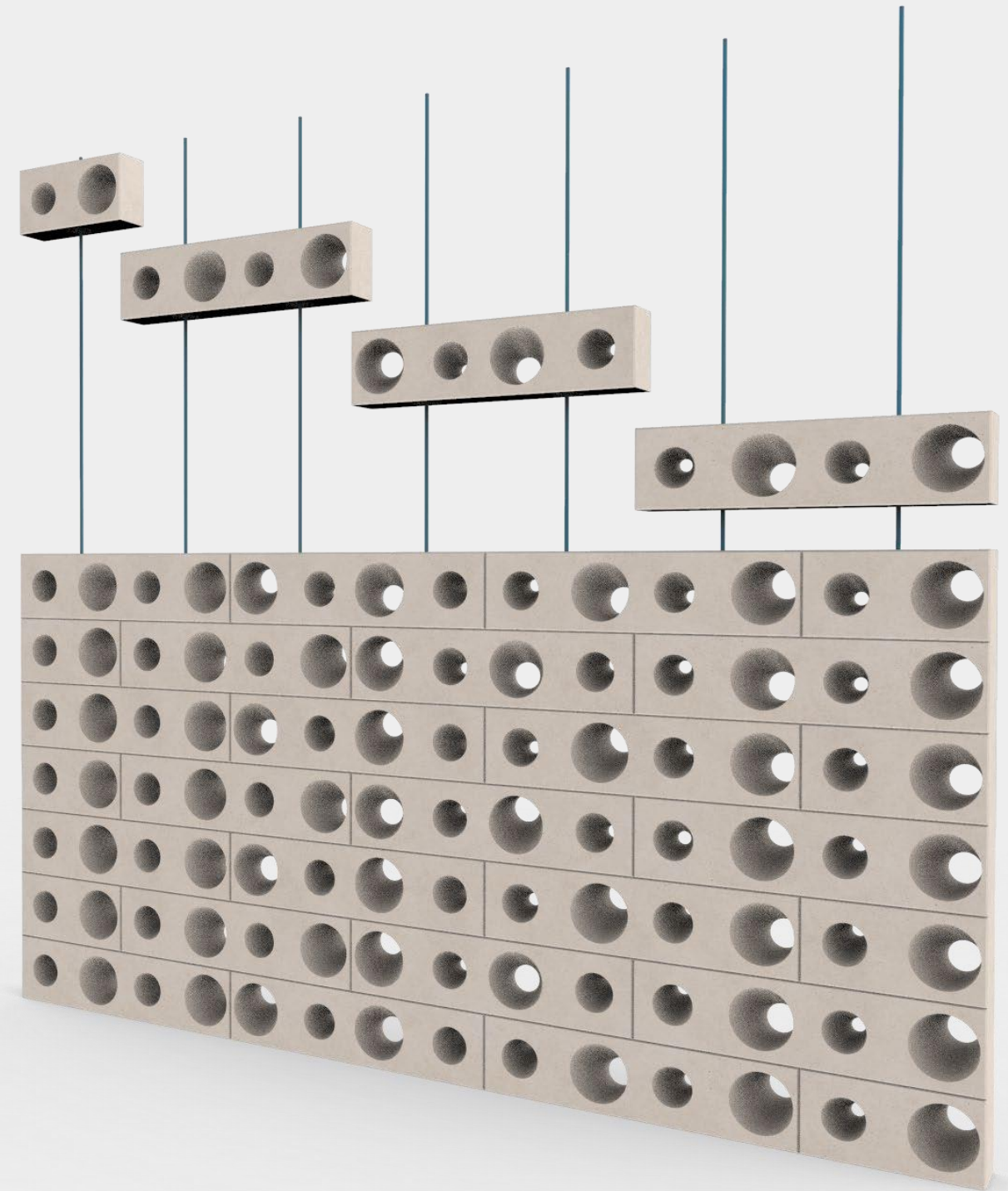

SOLIDS COLLECTION / AGATE REFERENCE

EXAMPLES OF MODULATIONS

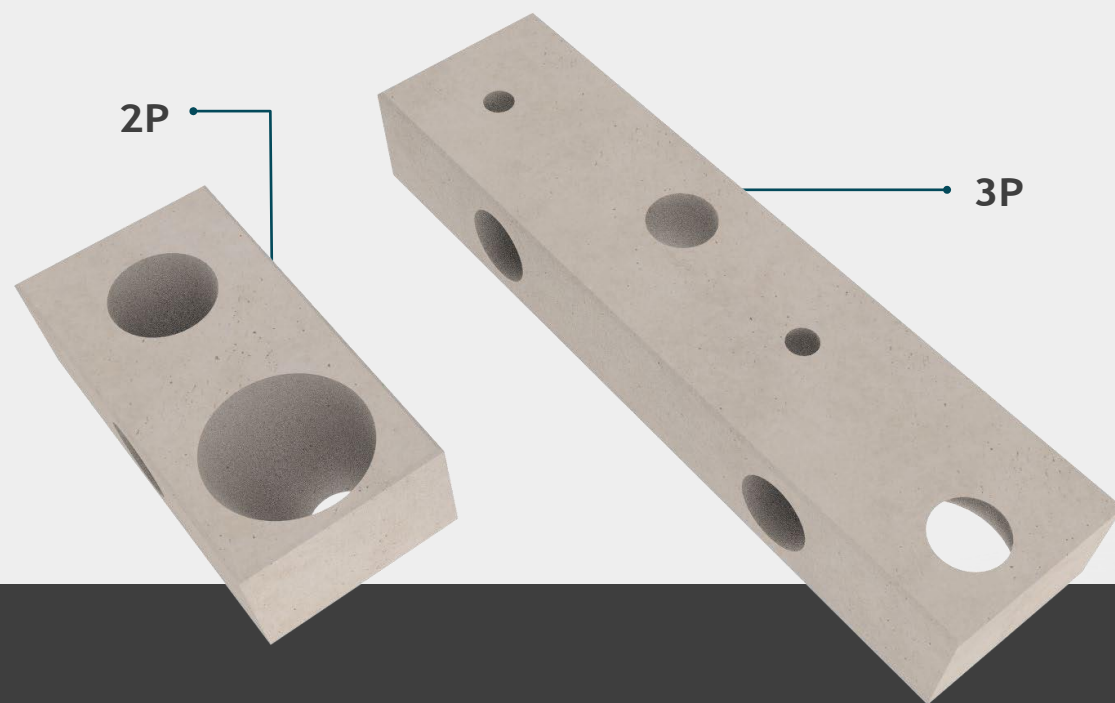

REF: AGATE 2

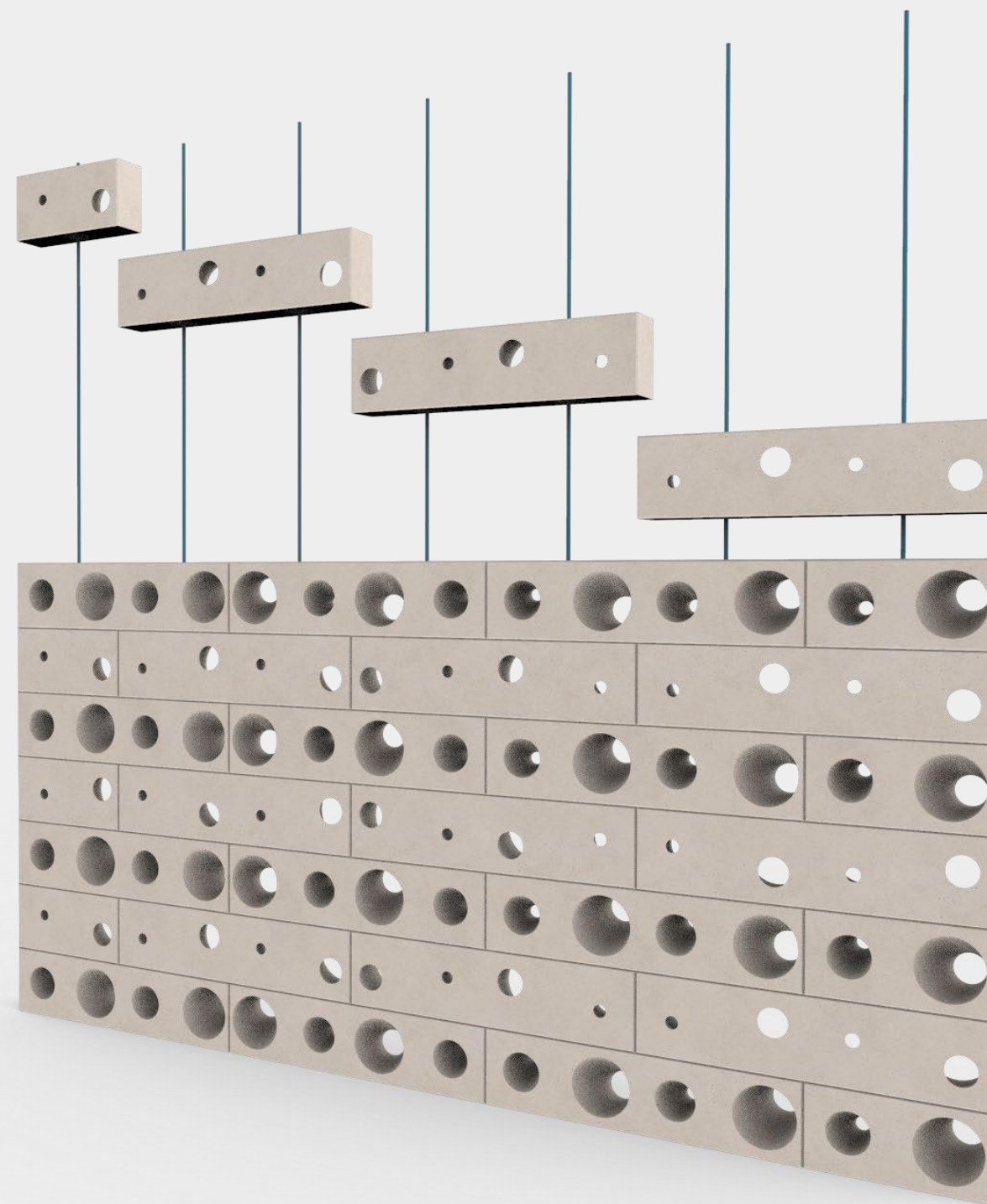

SOLIDS COLLECTION / AGATE REFERENCE

EXAMPLES OF MODULATIONS

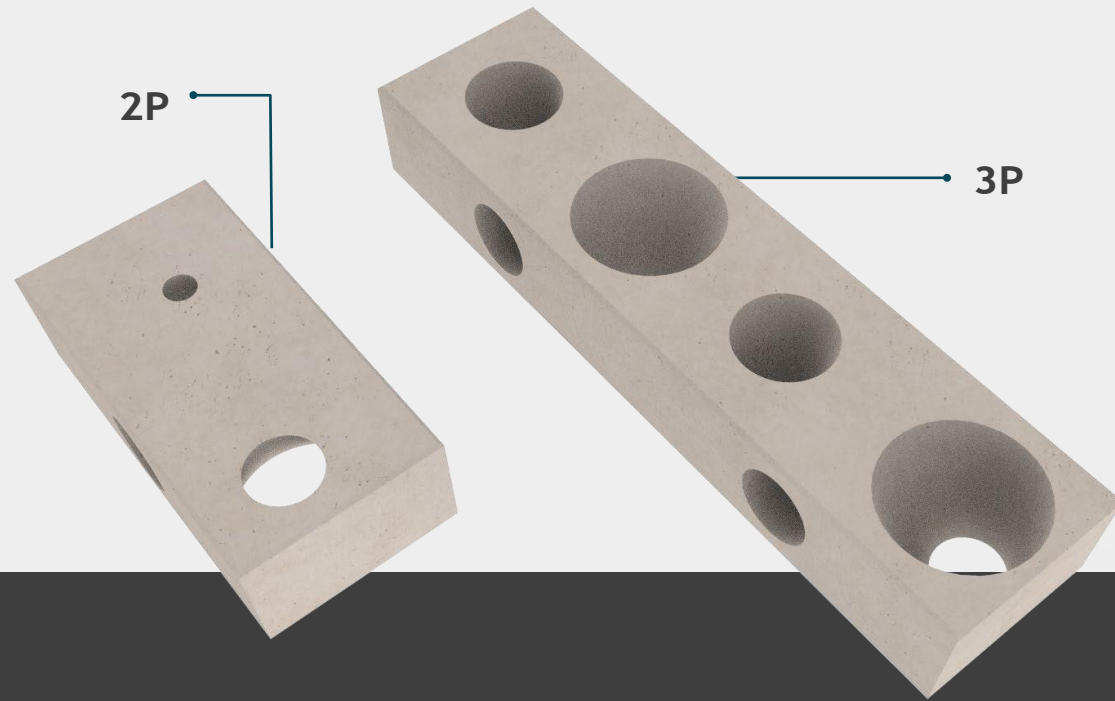

REF: AGATE 3

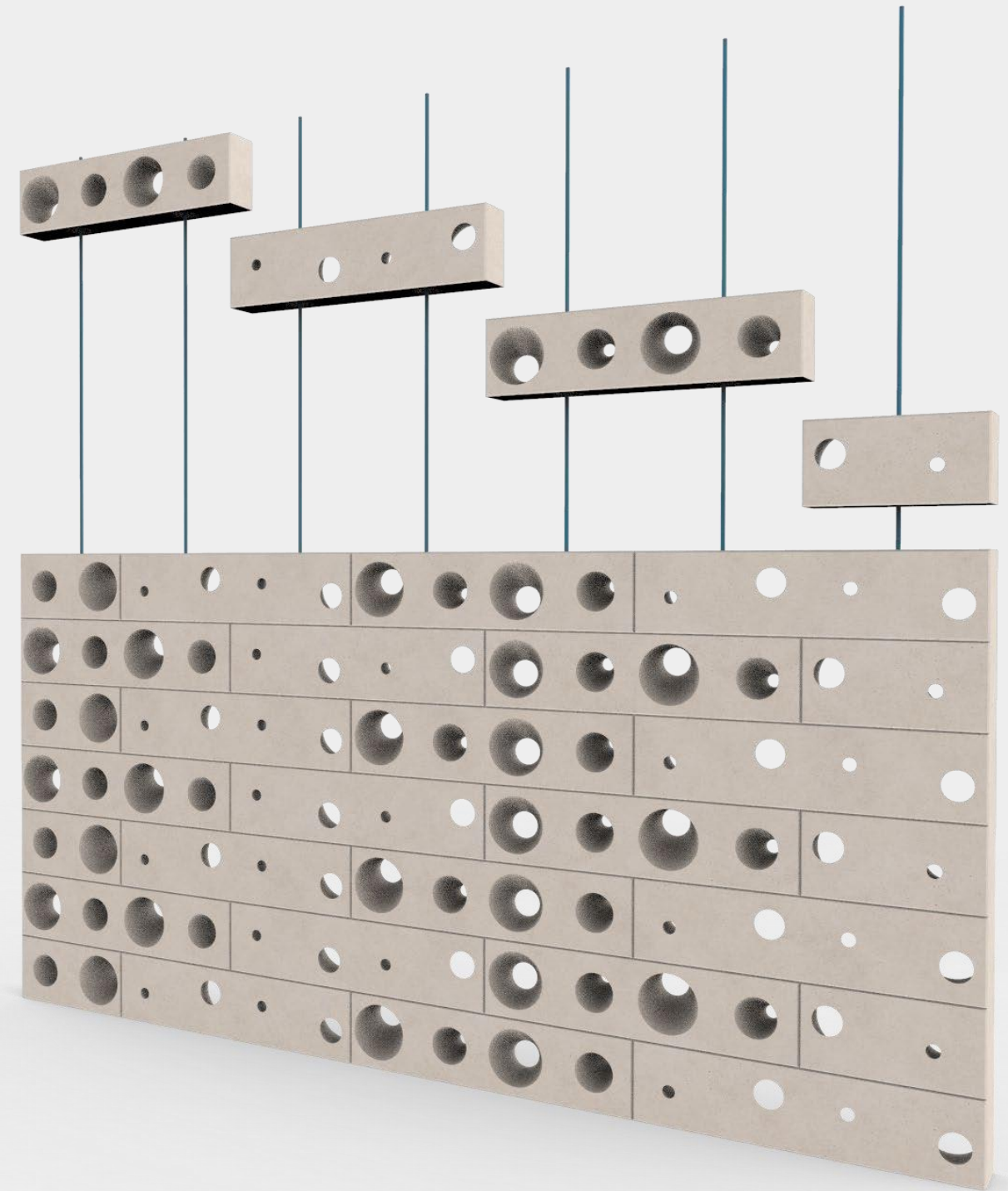

SOLIDS COLLECTION

HUMAN SCALE RELATIONSHIP

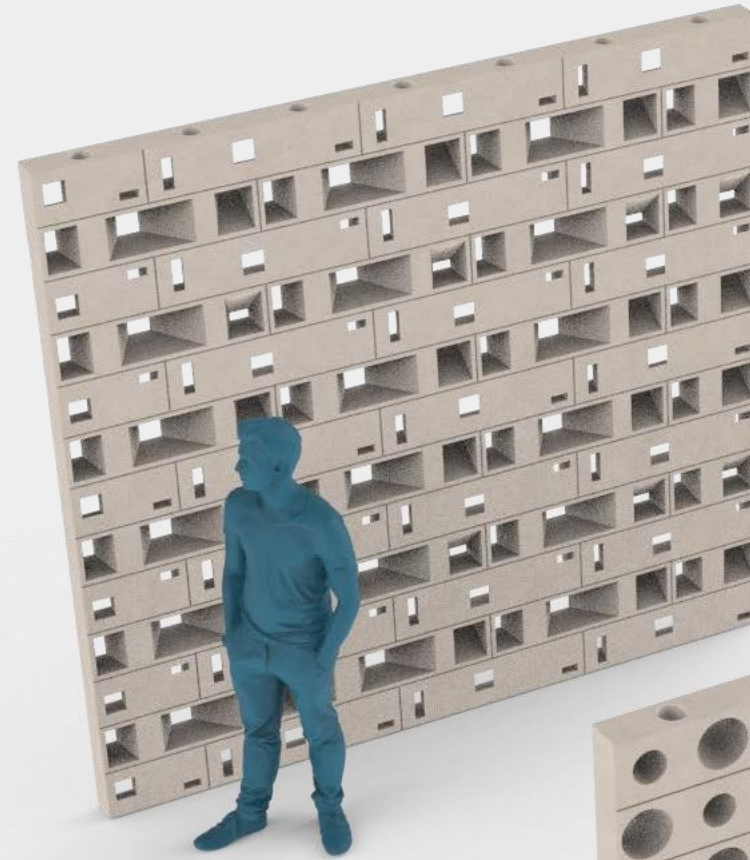

SAPPHITE REFERENCE

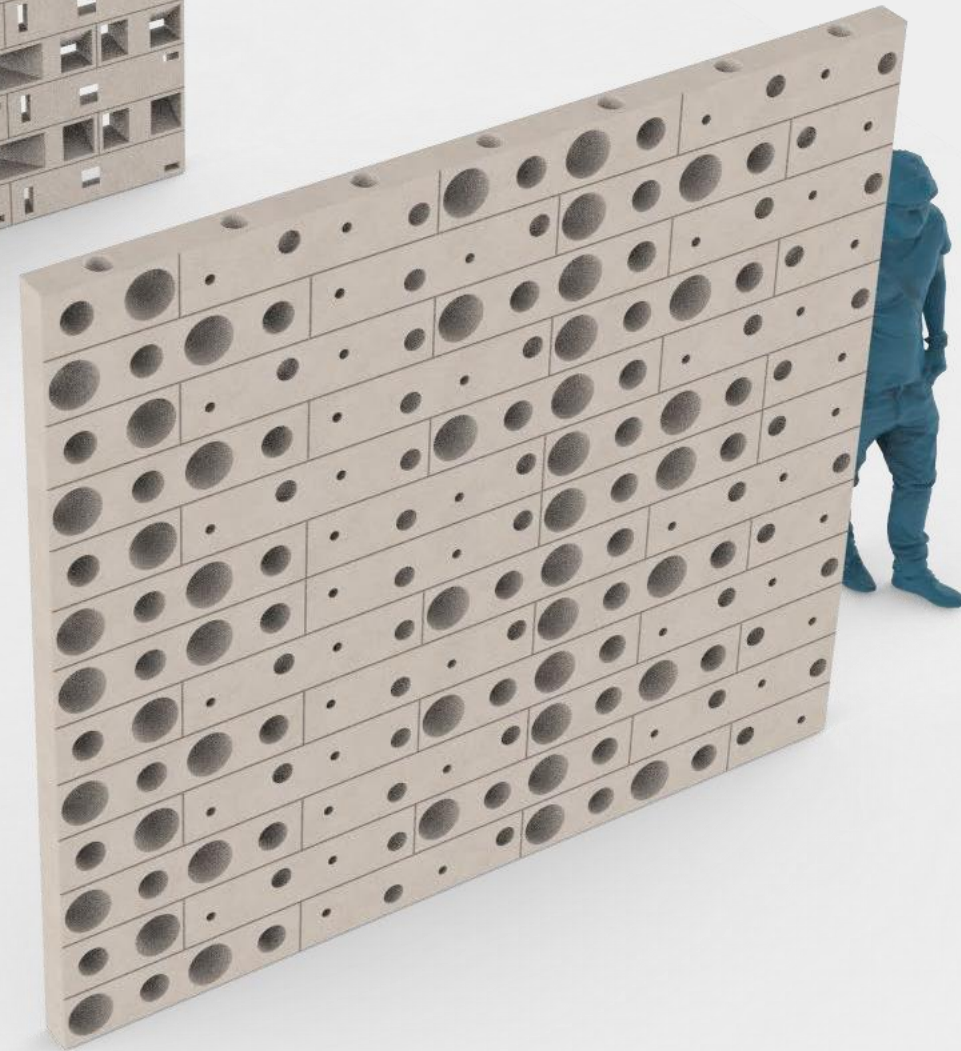

AGATE REFERENCE

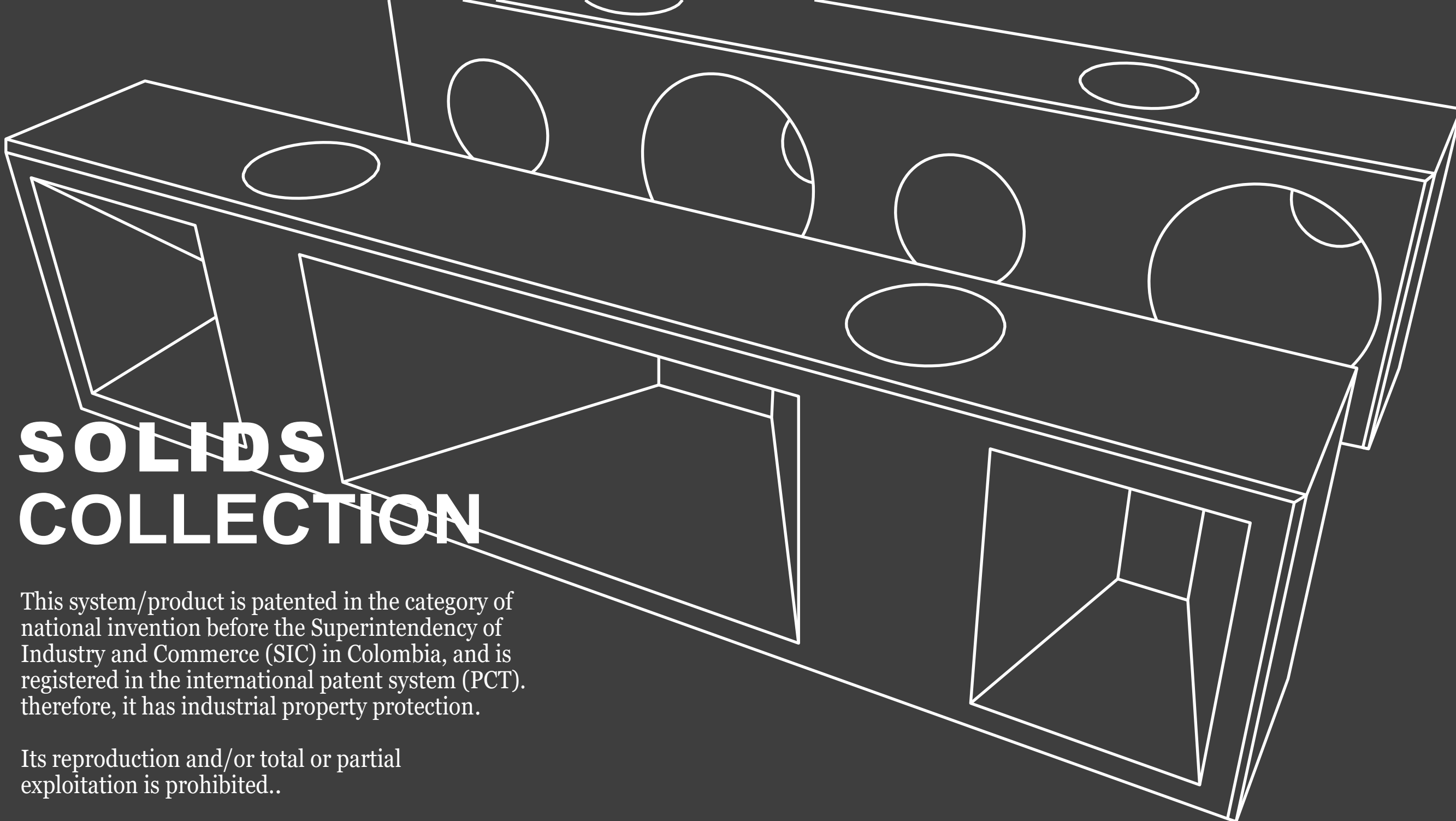

SOLIDS COLLECTION

This system/product is patented in the category of national invention before the Superintendency of Industry and Commerce (SIC) in Colombia, and is registered in the international patent system (PCT). therefore, it has industrial property protection.

Its reproduction and/or total or partial exploitation is prohibited..